

MP PUMPS, INC.

PETROLEUM 40

Self-Priming Centrifugal Pump

Specifically designed for transfer of petroleum based fluids, MP's *Petroleum 40* series is available in three (3) distinct models: **PO 40**, **PG 40** and **PE 40**.

The Petroleum 40 is available in pedestal mount for flexible coupling. Models are self-priming and capable of 20 foot suction lift.



SPECIFICATIONS:

Suction and Discharge	4" x 4"
Housing	PO 40 . . . Cast Iron, Ductile Iron (optional) PG 40 . . . Ductile Iron PE 40 . . . Ductile Iron
Impeller, Semi-Open. PO 40 . . .	Cast Iron PG 40 . . . Cast Iron, Aluminum (optional) PE 40 . . . Cast Iron, 316 SS (optional)
Wear Plate	PO 40 . . . Steel PG 40 . . . Aluminum PE 40 . . . Steel
Mechanical Seal . . .	PO 40 . . . Type 21 Viton/Carbon/NiResist/SS PG 40 . . . Type 2 Viton/Carbon/Silicon Carbide/SS PE 40 . . . Type 2 Viton/Carbon/Silicon Carbide/SS
Gasket, Flange	Composite
Fasteners	Stainless Steel

COMPATIBLE FOR:

- **PO 40** - Biodiesel, Fuel Oil, Diesel
- **PG 40** - Gasoline, Avgas, Kerosene, Jet A/8
- **PE 40** - Ethanol, E 85

MOUNTING OPTIONS:

Pedestal

PERFORMANCE TO:

710 GPM 232 HD. FT. @ 3450 RPM
620 GPM 56 HD. FT. @ 1750 RPM

PETROLEUM 40

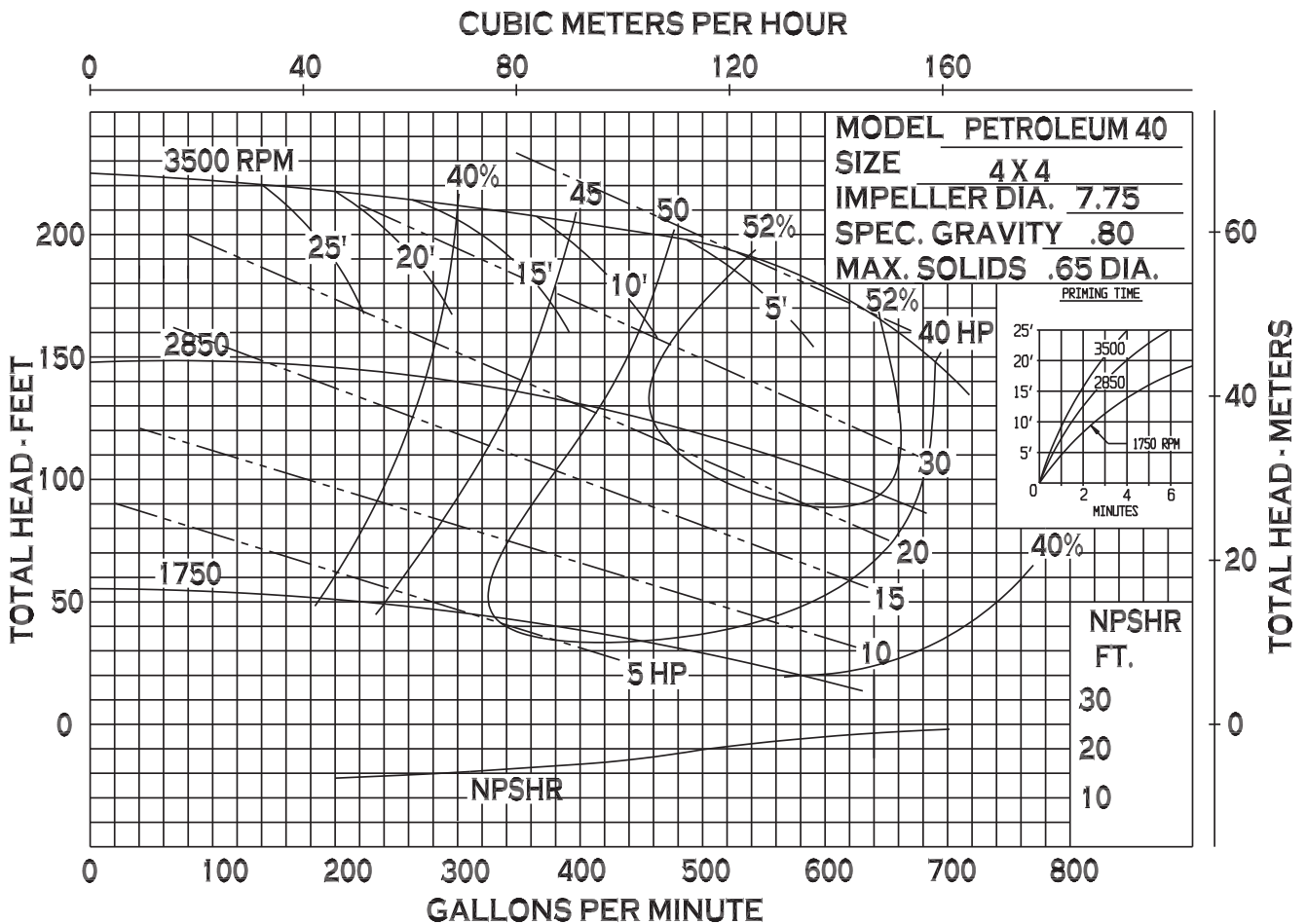
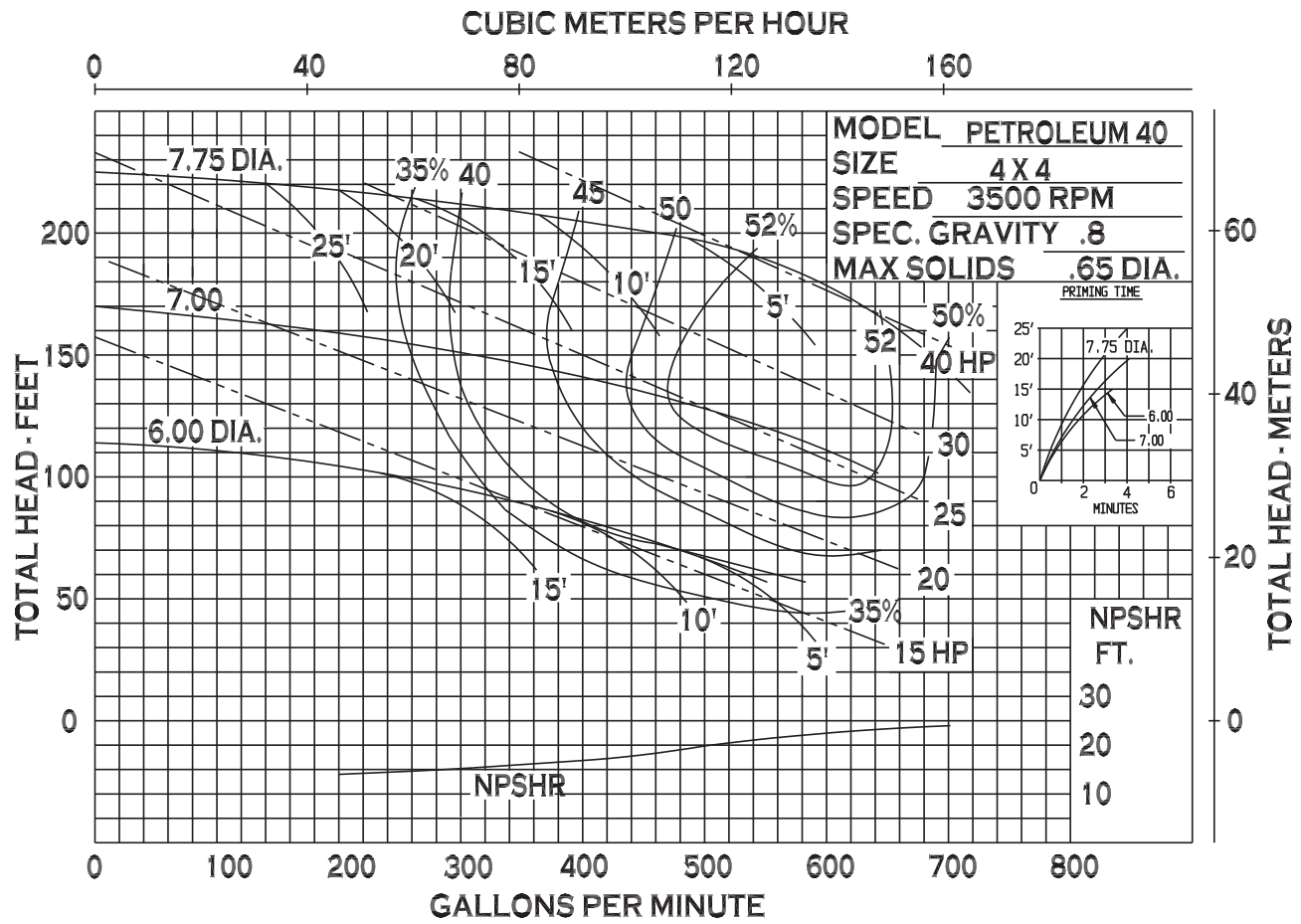

PEDESTAL-MOUNT

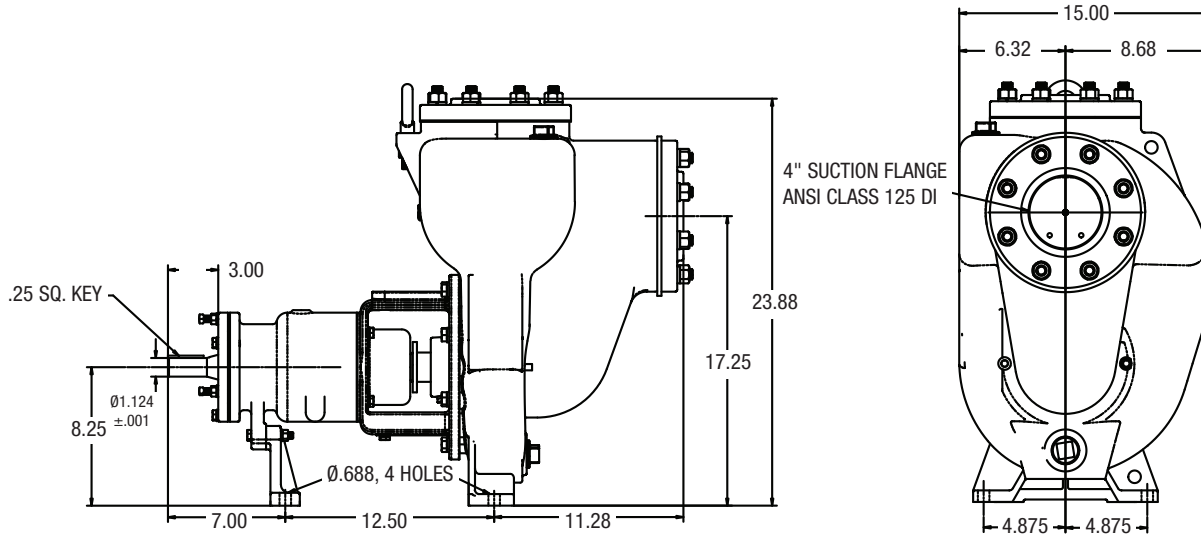

34800 BENNETT • FRASER, MI 48026-1686
(586) 293-8240 • FAX (586) 293-8469
(800) 563-8006 • www.mppumps.com

www.mppumps.com

FORM 8143-A (04/08)
Litho in USA