



CYCLONE SEPARATOR TRAP

MODEL DC3S

Benefits

Super cyclone-effect separator and steam trap combination unit provides high-quality dry steam.

1. Patented SCE separator's efficiency can deliver high quality steam of up to 99.8% dryness.
2. Self-modulating free float steam trap discharges condensate immediately.
3. Precision ground spherical float and positive three-point seating provide a complete seal, even under no-load conditions.
4. The large surface area of the built-in screen guarantees trouble-free service.
5. Only one moving part, the free float, reduces valve wear and increases service life.



U.S. Pat. 4,723,970

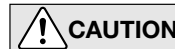

CAUTION DO NOT DISASSEMBLE OR REMOVE THIS PRODUCT WHILE IT IS UNDER PRESSURE. Allow internal pressure of this product to equal atmospheric pressure and its surface to cool to room temperature before disassembling or removing. Failure to do so could cause burns or other injury. READ INSTRUCTION MANUAL CAREFULLY.

Specifications

Model	DC3S		DC3*
Connection	Screwed	Flanged	Flanged
Size (in)	1/2, 3/4, 1	1 1/2, 2, 3, 4	6
Orifice No.		10, 21	—
Maximum Operating Pressure (psig) PMO		150, 300	300
Maximum Differential Pressure (psi) ΔPMX		150, 300	—
Max. Operating Temperature (°F) TMO		428	428
Max. Allowable Pressure (psig) PMA		300	300
Max. Allowable Temperature (°F) TMA		428	428



To avoid abnormal operation, accidents or serious injury, DO NOT use this product outside of the specification range. Local regulations may restrict the use of this product to below the conditions quoted.

* DC3: without steam trap

Connections and sizes in bold are standard

No.	Description*	Material	ASTM/AISI**	JIS
①	Body	Ductile Cast Iron	A536 Gr.65-45-12	FCD450
②	Separator Body	Ductile Cast Iron	A536 Gr.65-45-12	FCD450
③	Trap Cover	Ductile Cast Iron	A536 Gr.65-45-12	FCD450
④	Separator (1/2" - 2")	Cast Stainless Steel	A351 Gr.CF8	SCS13
④	Separator (3", 4", 6")	Ductile Cast Iron	A536 Gr.65-45-12	FCD450
⑤	Float	Stainless Steel	AISI316L	SUS316L
⑥	Float Cover (1/2" - 2")	Cast Iron	A126 Cl.B	FC250
⑥	Float Cover (3", 4", 6")	Ductile Cast Iron	A536 Gr.65-45-12	FCD450
⑦	Guide Pin	Stainless Steel	AISI304	SUS304
⑧	Trap Valve Seat	—	—	—
⑨	Valve Seat Gasket	Fluorine Resin	PTFE	PTFE
⑩	Trap Cover Gasket	Fluorine Resin	PTFE	PTFE
⑪	Wave Spring	Stainless Steel	AISI301	SUS301
⑫	Body Gasket	Fluorine Resin	PTFE	PTFE
⑬	Screen	Stainless Steel	AISI304	SUS304
⑭	Bushing	Stainless Steel	AISI303	SUS303
⑮	Float Cover Bolt	Carbon Steel	AISI1045	S45C
⑯	Spring Washer	Stainless Steel	AISI304	SUS304
⑰	Body Bolt	Carbon Steel	AISI1045	S45C
⑱	Trap Cover Bolt	Carbon Steel	AISI1045	S45C
⑲	Nameplate	Stainless Steel	AISI304	SUS304
⑳	Baffle***	Stainless Steel	AISI304	SUS304
㉑	Baffle Bolt***	Stainless Steel	AISI304	SUS304
㉒	Baffle Nut***	Stainless Steel	AISI304	SUS304

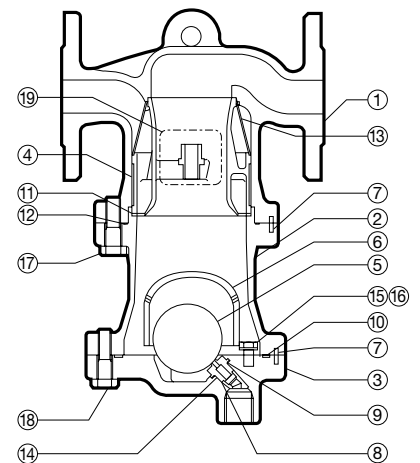

1/2" - 2" DC3S shown. 3", 4" DC3S and 6" DC3 configuration differs slightly.

* Parts shown are for the DC3S, some parts may not apply for the DC3

** Equivalent *** 3" - 6", above float cover, not shown

Dimensions

● **DC3S** Screwed

● **DC3S** Flanged

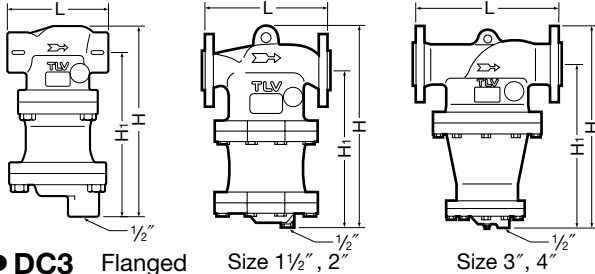

● **DC3** Flanged

Size 1 1/2", 2"

Size 3", 4"

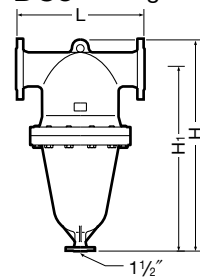

DC3, 6" requires the installation of an external steam trap. Condensate discharge capacity depends on the trap used.

DC3S Screwed* (in)

Size	L	H	H ₁	Weight (lb)
1/2	5 7/8	9 9/16	8 1/4	13
3/4				
1	6 11/16	10 15/16	9 1/2	21

* NPT, other standards available

DC3S Flanged (in)

Size	L		H	H ₁	Weight** (lb)
	ASME Class	300RF			
1 1/2	8 9/16	8 7/8	13 7/8	10 9/16	40
2	10 1/8	10 3/8	16 7/16	12 5/8	69
3	14 3/4	15 1/8	20 1/2	16 15/16	165
4	17 1/16	17 11/16	25 5/8	20 1/2	265
6*	25 5/8	—	43 3/4	37 7/8	816
	—	26 9/16	43 7/8	38	

Other standards available, but length and weight may vary

* DC3 ** Weight is for Class 300 RF

Flange classes in bold are standard

Steam Flow Rate

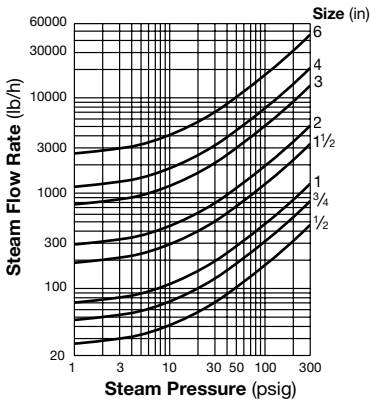

The chart at the left is used to determine the steam flow rate through the DC3S separator. It is based on a steam velocity in the piping of 100 ft/sec. For other velocities, calculate the flow rate as follows:
 Flow rate at V ft/sec = flow rate at 100 ft/sec × $\frac{V}{100}$
 It is recommended that velocities not exceed 100 ft/sec.

Pressure Loss

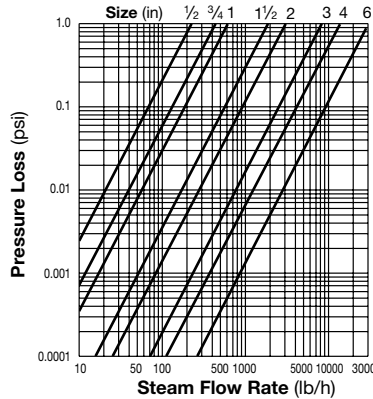

The pressure loss chart is based on a steam pressure of 150 psig. For other pressures, multiply the steam flow rate by the correction factor given in the table below. Use the result on the pressure loss chart.

Condensate Discharge Capacity

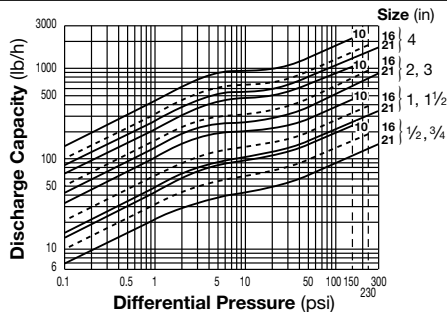

— Standard
 - - - - - Available on special request

1. Line numbers within the left-hand graph refer to orifice numbers.
2. Differential pressure is the difference between the separator inlet and its trap outlet pressure.
3. Capacities are based on continuous discharge of condensate 11°F below saturated steam temperature.
4. Recommended safety factor: at least 1.5.

CAUTION DO NOT use traps under conditions that exceed maximum differential pressure, as condensate backup will occur!

TLV CORPORATION

13901 South Lakes Drive, Charlotte, NC 28273-6790
 Phone: 704-597-9070 Fax: 704-583-1610
 E-mail: tl@tlvengineering.com
 For Technical Service 1-800 "TLV TRAP"



Manufacturer
TLV CO., LTD.
 Kakogawa, Japan
 is approved by LRQA Ltd. to ISO 9001/14001

ISO 9001/ISO 14001

