



VORTEX FLOWMETER

MODEL EF73

RELIABLE FLOW MEASURING SYSTEM FOR GAS, STEAM AND LIQUIDS

Features

High-performance vortex flowmeter with robust sensor for highly accurate volume or mass flow measurements of steam, liquids and gasses.

1. DSC (Differential Switched Capacitance) sensor offers a wide measuring range, with a high resistance to thermal shock, vibration and water hammer.
2. Integrated flow computer calculates mass flow from measured volume flow and temperature variables.
3. Capable of simultaneous pulse (interval) and analog (instantaneous) output.
4. Requires no maintenance, has no moving parts, and experiences no zero point drift.
5. Low pressure drop through body.



Specifications

Meter Body / Sensor

Model		EF73	
Connection		Flangeless	Flanged
Size (in)		1/2, 1, 1 1/2, 2, 3, 4, 6	1/2, 1, 1 1/2, 2, 3, 4, 6, 8, 10, 12
Connection Compatibilities		See details in the Dimensions section	
Operating Pressure Range (psig)		0 – 725 (See the table to the right for details)	
Temperature Range (°F)		-330 ¹⁾ – +750 (See the table to the right for details)	
Applicable Fluid ²⁾		Steam, Air, Water and others ³⁾	
Accuracy	Volume Flow	Gas/Steam: ± 1% of reading (Re > 20 000), ± 1% of full scale (Re: 4 000 – 20 000) Liquid: ± 0.75% of reading (Re > 20 000) ± 0.75% of full scale (Re: 4 000 – 20 000)	
	Mass Flow	Saturated ± 2% of reading ⁴⁾ (Re > 20 000) Steam: ± 2% of full scale ⁴⁾ (Re: 4 000 – 20 000)	
Repeatability		Within 0.25% of reading	
Vibration Resistance		At least 1G in all directions (10 – 500 Hz)	
Mounting Position		No restriction with regards to meter accuracy	

- 1) Subject to the limitations of fluid freezing point 2) For superheated steam, air and other gasses, an external pressure sensor and flow computer may be required if inlet pressure fluctuates
3) Do not use for toxic, flammable or otherwise hazardous fluids 4) +0.3% for remote version

Transmitter

Explosion Class	Non-explosion proof
Ambient Temperature	Compact Type: -40 – +158 °F Remote Type: -40 – +185 °F
Ingress Resistance	IP 67 (NEMA 4X)
Output	Frequency (pulse) output: Open collector pulse (passive) Analog output: 4 – 20 mA DC
Power Source	12 – 36 V DC (24 V DC recommended)
Power Consumption	1.2 W DC (including sensor)
Power Line Connection	BSPF (G) 1/2
Field Wiring	2-wire System (2-conductor, shielded, at least 1.25 mm ²)
Load Line Resistance	Maximum 550Ω at 24 V



To avoid abnormal operation, accidents or serious injury, DO NOT use this product outside of the specification range. Local regulations may restrict the use of this product to below the conditions quoted.

Pressure/Temperature Operating Range

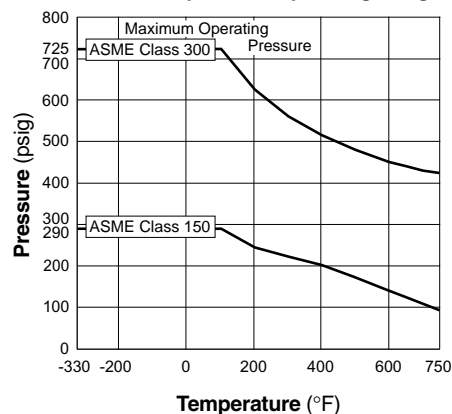

Reynolds Number (Re) Calculation:

$$Re = \frac{d \times V}{\nu}$$

d = pipe diameter V = velocity
ν = viscosity

Transmitter Terminals

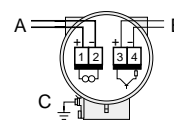

- A: Power supply/
current output
B: Optional frequency
output
C: Ground terminal
(for remote version)

Display

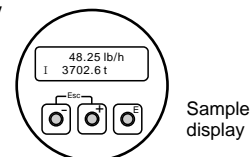

Specifications

No.	Description	Material	JIS*	ASTM/AISI
①	Meter Body	Cast Stainless Steel	SCS16A	A351 Gr. CF3M
②	Bluff Body	Cast Stainless Steel	SCS16A	A351 Gr. CF3M
③	DSC Sensor (wetted parts)	Stainless Steel (DIN 1.4435)	SUS316L	AISI316*
	DSC Sensor (non-wetted parts)	Stainless Steel (DIN 1.4301)	SUS304	AISI304*
④	Pipe Stand	Cast Stainless Steel	SCS13A	A351 Gr. CF8
⑤	Transmitter Housing	Die-cast Aluminum	-	-
⑥	Gasket	Graphite	-	-
⑦	Nameplate	-	-	-
⑧	Mounting Kit**	-	-	-
⑨	Remote Transmitter Mount***	Die-cast Aluminum	-	-
⑩	Connecting Cable (30 m)***	-	-	-

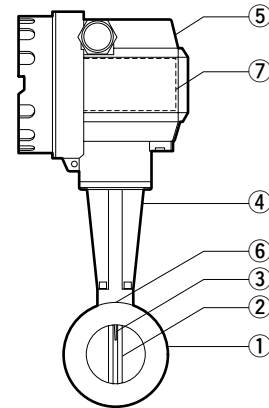

* Equivalent materials
 ** Flangeless model only, to ensure concentric installation; includes centering rings, threaded bolts, nuts, washers and flange gaskets
 *** Remote version only, see next page

Piping Installation

Required Straight Piping

Piping Element	Piping Example and Required Length of Straight Piping	Remarks
Reducer		When there is a concentric reducer upstream of meter
Expansion Pipe		When there is a concentric expansion pipe upstream of meter
Elbow		When there is an elbow upstream of meter
		When there are two elbows horizontally upstream of meter
		When there are two elbows vertically (3-dimensional) upstream of meter
Control Valve, Globe Valve, etc.		When there is a factor that suddenly disturbs flow upstream of meter
Flow Conditioner (Rectifier)		When a flow conditioner is installed upstream of meter
Pressure Measurement Points		If used, a pressure measurement point is to be mounted downstream of the meter as shown

D = Nominal diameter of piping

Mounting Position

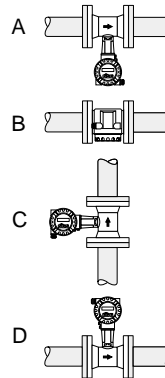

There is no restriction for mounting position (A – D) in regards to meter accuracy. However, special care is recommended for the following flow mediums:

- High-temperature Fluids**
For high-temperature fluids (steam, condensate), positions A, B or C should be selected to protect the transmitter form heat.
- Liquids**
To make sure the pipes are completely flooded with liquid, position C is recommended.

Pipeline Insulation

The pipe stand serves as a radiator and protects the electronics from overheating. Therefore, ensure that sufficient surface area remains exposed. Be sure not to insulate passed the level marked "max." on the pipe stand.

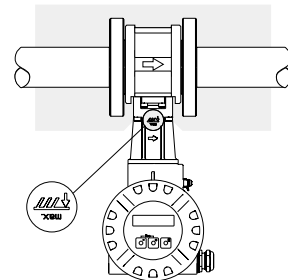

Ensuring Steam Quality

Wet steam has a higher density than saturated steam. Since the flowmeter mass flow calculations are based on saturated steam density, the actual mass flow of wet steam will be higher than shown by the flowmeter. The upstream installation of a separator (DC3S) is suggested to ensure steam quality and flowmeter accuracy. The proper separation and drainage of condensate is a recommended practice for all steam applications.

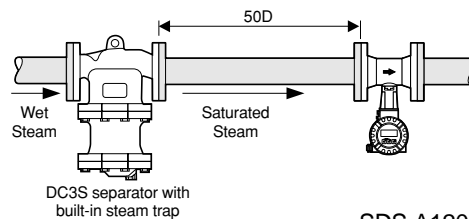

Dimensions

● **EF73 Flangeless Compact Version**

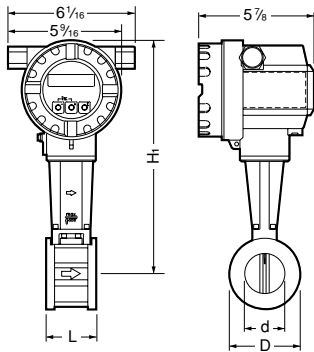

Remote Version

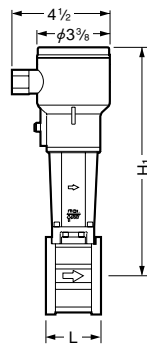

EF73 Flangeless* (in)

Size	L	φD	φd	H _i		Weight** (lb)
				Compact	Remote	
1/2	2 9/16	1 3/4	1 1/16	10 7/8	9 11/16	6.6
1		2 1/2	1 1/8	11 1/4	10 1/16	7.1
1 1/2		3 1/4	1 5/8	11 15/16	10 3/8	8.4
2		3 5/8	2 1/8	11 7/8	10 11/16	9.0
3		5	3 1/8	12 3/8	11 1/4	12
4		6 3/16	4 1/8	12 15/16	11 3/4	14
6	8 1/2	6 3/16	13 15/16	12 3/4	20	

* Compatible with ASME class 150, 300, JIS 10K/20K, and DIN 2501 PN10/16, 25/40 flange standards
 ** Weight is for compact version

● **EF73 Flanged Compact Version**

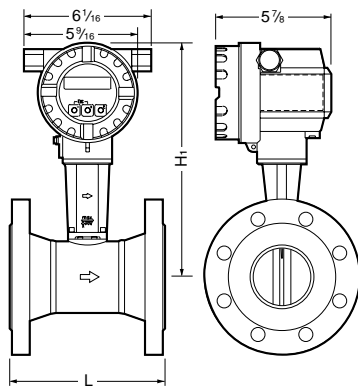

Remote Version

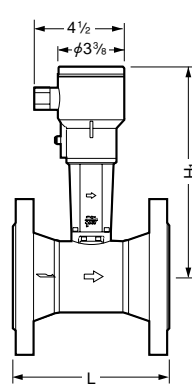

EF73 Flanged (in)

Size	L		H _i		Weight* (lb)
	ASME Class		Compact	Remote	
	150RF	300RF			
1/2	7 7/8	7 7/8	10 7/8	9 3/4	12
1			11 3/16	10	17
1 1/2			11 1/2	10 5/16	23
2			11 3/4	10 9/16	28
3			12 5/16	11 1/8	46
4			9 13/16	9 13/16	12 3/4
6	11 13/16	11 13/16	13 11/16	12 1/2	114
8			14 13/16	13 11/16	142 (164)
10	14	14	15 7/8	14 3/4	204 (241)
12	17 11/16	17 11/16	16 13/16	15 5/8	316 (358)

Other standards available, but weight may vary
 * Weight is for compact version
 () ASME Class 300 RF

● **EF73 Remote Transmitter**

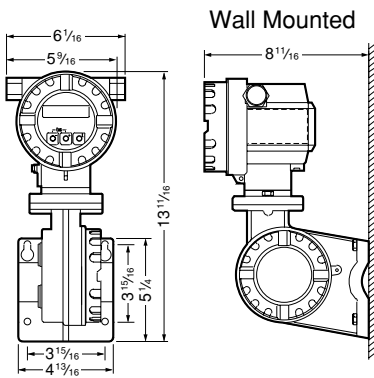

Remote transmitter weight: 7.7lb

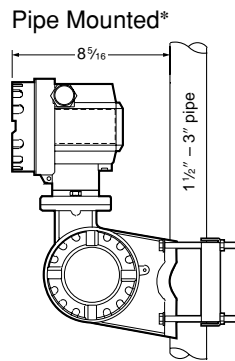

* Requires optional parts

Remote Transmitter to Sensor Wiring

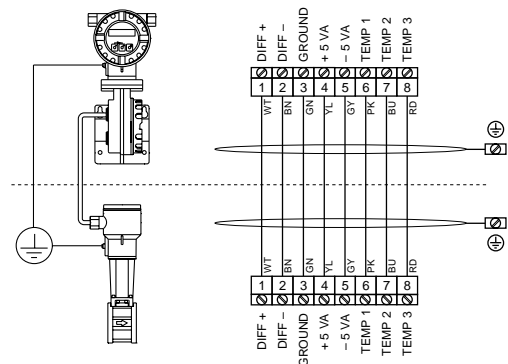

Options

① Pipe Mounting Kit

Suitable for 1 1/2" - 3" pipe.
 (Includes bracket, threaded bolts and nuts.)

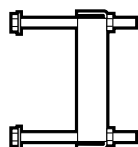

② Sunshade for Transmitter

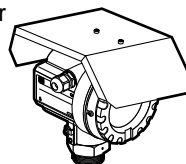

③ Flow Conditioner

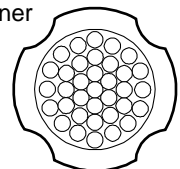

Flow Rate for Saturated Steam

● EF73 Flangeless

(Unit: lb/h)

Size (in)	1/2		1		1 1/2		2		3		4		6		Temp. (°F)
	Min.	Max.	Min.	Max.	Min.	Max.	Min.	Max.	Min.	Max.	Min.	Max.	Min.	Max.	
10	10.1	54.5	28.1	321	75.9	760	124	1252	277	2756	472	4753	1057	10785	239
20	11.8	74.9	32.9	442	88.9	1045	145	1721	325	3789	554	6535	1239	14828	259
30	13.3	95.0	37.1	560	101	1324	163	2182	366	4805	623	8286	1395	18802	274
40	14.6	114	40.8	677	111	1601	179	2638	402	5807	685	10015	1534	22726	287
50	15.8	134	44.2	793	120	1875	194	3089	435	6801	742	11728	1660	26612	298
60	16.9	153	47.2	907	128	2146	207	3537	466	7786	794	13428	1776	30470	307
80	18.9	192	52.8	1136	143	2685	232	4424	521	9741	888	16799	1987	38119	324
100	20.7	230	57.8	1362	157	3220	254	5305	571	11680	972	20143	2175	45706	338
150	24.6	326	68.7	1923	186	4545	302	7489	678	16489	1155	28436	2585	64524	366
200	27.9	420	78.1	2481	211	5865	342	9664	770	21276	1311	36692	2936	83258	388
250	30.9	515	86.4	3039	234	7186	379	11839	852	26067	1451	44954	3249	102004	406
300	33.6	610	94.0	3600	254	8511	412	14023	927	30875	1580	53246	3536	120820	422
350	36.2	706	101	4164	274	9844	443	16220	997	35712	1699	61587	3803	139746	436
400	39.0	1115	108	5091	292	11789	473	19129	1063	43041	1811	73333	4054	164214	448

● EF73 Flanged

(Unit: lb/h)

Size (in)	1/2		1		1 1/2		2		3		4		6		8		10		12		Temp. (°F)
	Min.	Max.	Min.	Max.	Min.	Max.	Min.	Max.	Min.	Max.	Min.	Max.	Min.	Max.	Min.	Max.	Min.	Max.	Min.	Max.	
10	7.2	53.3	21.8	268	62.5	659	105	1009	234	2466	405	4271	921	9717	1767	18654	2786	29404	3995	41930	239
20	8.4	73.2	25.6	368	73.2	906	123	1510	274	3390	475	5872	1080	13359	2072	25645	3266	40428	4683	57635	259
30	9.5	92.9	28.8	467	82.5	1148	138	1915	309	4298	535	7446	1216	16939	2333	32517	3678	51260	5275	73135	274
40	10.4	112	31.6	564	90.7	1388	152	2315	340	5195	588	9000	1336	20474	2565	39304	4043	61959	5799	88400	287
50	11.2	131	34.2	661	98.1	1626	164	2711	367	6084	636	10540	1446	23976	2776	46026	4375	72556	6274	103450	298
60	12.0	150	36.6	757	105	1861	175	3104	393	6966	681	12067	1547	27452	2970	52698	4682	83074	6715	118508	307
80	13.4	188	41.0	947	118	2329	196	3884	440	8715	761	15097	1731	34344	3322	65929	5236	103932	7511	148117	324
100	14.7	225	44.9	1136	129	2792	215	4657	481	10450	833	18103	1895	41181	3638	79053	5734	124621	8224	177643	338
150	17.5	318	53.3	1603	153	3942	255	6574	572	14753	990	25556	2252	58136	4322	111601	6813	175928	9772	250844	366
200	19.8	411	60.5	2069	174	5087	290	8483	649	19036	1125	32975	2558	75011	4909	143996	7738	226995	11099	323588	388
250	21.9	504	67.0	2535	192	6232	321	10392	719	23320	1245	40396	2831	91894	5433	176404	8565	278085	12285	396732	406
300	23.9	597	72.9	3002	209	7381	349	12309	782	27620	1355	47845	3081	108838	5913	208930	9321	329359	13370	469782	422
350	25.7	690	78.4	3472	225	8537	375	14236	841	31945	1457	55336	3313	125880	6359	241645	10024	380930	14378	538924	436
400	28.0	784	84.0	3946	240	9701	400	16178	897	36302	1553	62883	3532	143049	6779	274601	10686	432883	15327	620905	448

Flow Rate for Air and Water

(Unit: Air: SCMF Water: GPM)

Model	EF73 Flangeless				EF73 Flanged			
	Air (68 °F, atmospheric pressure)		Water (68 °F)		Air (68 °F, atmospheric pressure)		Water (68 °C)	
	Min.	Max.	Min.	Max.	Min.	Max.	Min.	Max.
1/2	2.5	20.6	0.9	30.3	1.8	14.1	0.7	21.5
1	7.1	94.7	1.9	83.6	5.3	73.5	1.4	66.0
1 1/2	18.3	220	4.9	193	15.3	180	4.1	158
2	29.5	356	7.9	317	25.4	301	6.7	268
3	66.6	803	17.8	717	56.0	677	15.0	607
4	113	1368	30.3	1228	96.6	1174	26.0	1052
6	252	3066	67.8	2752	220	2670	59.5	2395
8	-	-	-	-	421	5127	114	4601
10	-	-	-	-	664	8038	179	7256
12	-	-	-	-	952	11593	257	10409

Contact TLV for the flow rates of other fluids.

TLV CORPORATION

13901 South Lakes Drive, Charlotte, NC 28273-6790
 Phone: 704-597-9070 Fax: 704-583-1610
 E-mail: tlv@tlvengineering.com
 For Technical Service 1-800 "TLV TRAP"



TLV CO., LTD.
 Kakogawa, Japan
 is approved by LRQA Ltd. to ISO 9001/14001

ISO 9001/ISO 14001

