



THERMOSTATIC AIR VENT FOR STEAM

MODEL LA21

ALL STAINLESS STEEL BALANCED PRESSURE THERMOSTATIC AIR VENTS

Benefits

Maintainable and compact stainless steel air vents for service in steam mains and process or heating equipment.

1. High capacity air venting at close-to-steam temperatures for fast start-ups.
2. Reacts immediately to changes in operating conditions for maximum production performance.
3. Hardened stainless steel valve head and seat promotes longevity.
4. Positive open-close operation reduces valve wear for improved reliability.
5. "Pressure-to-close" valve design improves life.
6. Valve, four diaphragms and casing have matching contours for high superheat capability and water hammer resistance.
7. Large screen promotes trouble-free service.
8. Flat mirror-finish valve head provides tightest sealing for energy efficiency and long life.
9. Compact for easy installation.
10. Maintainable design lowers cleaning cost.



CAUTION DO NOT DISASSEMBLE OR REMOVE THIS PRODUCT WHILE IT IS UNDER PRESSURE. Allow internal pressure of this product to equal atmospheric pressure and its surface to cool to room temperature before disassembling or removing. Failure to do so could cause burns or injury. READ INSTRUCTION MANUAL CAREFULLY.

Specifications

Model	LA21	
Connection	Screwed	
Size (in)	1/2	
Max. Operating Pressure (psig)	PMO	300
Min. Operating Pressure (psig)	1.5	
Max. Operating Temp. (°F)	TMO	see graph at right
Max. Allowable Pressure (psig)	PMA	900
Max. Allowable Temperature (°F)	TMA	800
Subcooling of X-element Fill (°F)	up to 40	
Type of X-element	T	

Connections and sizes in hold are standard



To avoid abnormal operation, accidents or serious injury, DO NOT use this product outside of the specification range. Local regulations may restrict the use of this product to below the conditions quoted.

No.	Description	Material	ASTM/AISI*	JIS
①	Body Upper Part	Cast Stainless Steel	A351 Gr.CF8	—
②	Body Lower Part	Cast Stainless Steel	A351 Gr.CF8	—
③	X-element	Stainless Steel	—	—
④	Valve Seat	Stainless Steel	AISI630	SUS630
⑤	Screen	Stainless Steel	AISI304	SUS304
⑥	Spring Clip	Stainless Steel	AISI304	SUS304
⑦	Nameplate	Stainless Steel	AISI304	SUS304

* Equivalent

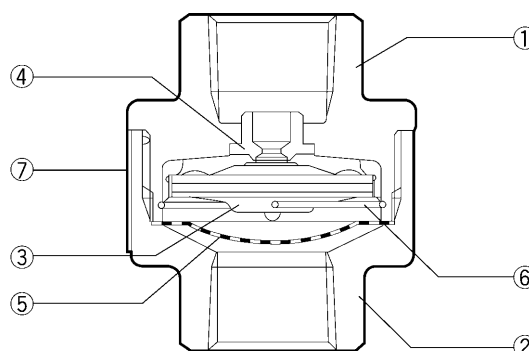
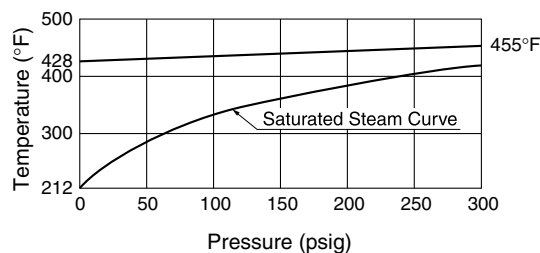

Dimensions

● **LA21** Screwed

LA21 Screwed* (in)

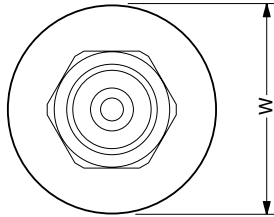

Size	L	ϕW	Weight (lb)
1/2	2 3/16	1 7/8	0.9

* NPT, other standards available

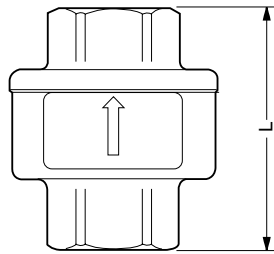

Air Venting Capacity

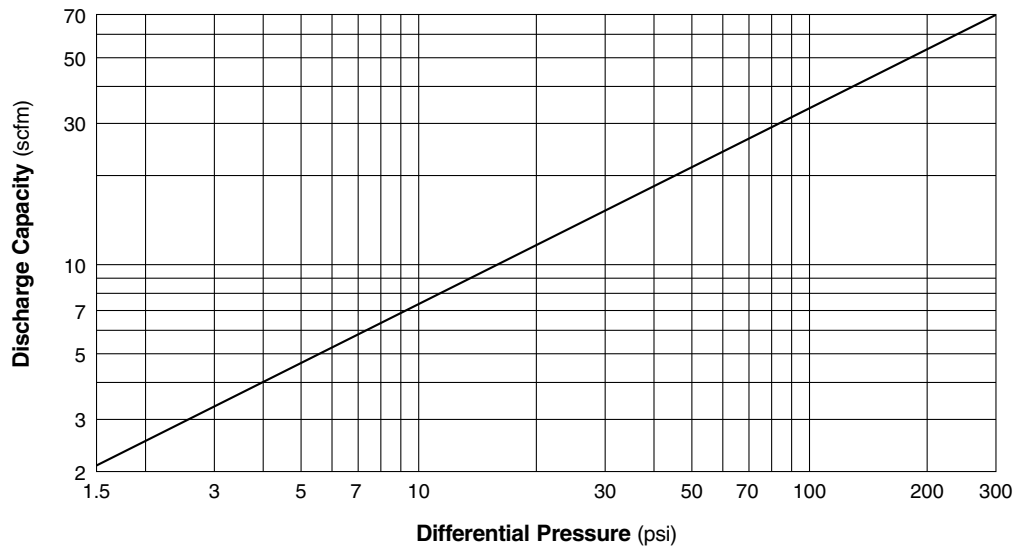

1. Differential pressure is the difference between the inlet and outlet pressure of the air vent.
2. Capacities are equivalent capacities of standard air (air at 68 °F and atmospheric pressure).

TLV CORPORATION

13901 South Lakes Drive, Charlotte, NC 28273-6790
 Phone: 704-597-9070 Fax: 704-583-1610
 E-mail: tlv@tlvengineering.com
 For Technical Service 1-800 "TLV TRAP"



Manufacturer
TLV CO., LTD.
 Kakogawa, Japan
 is approved by LRQA Ltd. to ISO 9001/14001

ISO 9001/ISO 14001

